

*June 1999*



***Biology 30***  
***Grade 12 Diploma Examination***



*June 1999*

# ***Biology 30***

## ***Grade 12 Diploma Examination***

### ***Description***

Time: 2.5 h. This examination was developed to be completed in 2.5 h; however, you may take an additional 0.5 h to complete the examination.

This is a **closed-book** examination consisting of

- 48 multiple-choice and 8 numerical-response questions, of equal value, worth 70% of the examination
- 2 written-response questions, of equal value, worth 30% of the examination

This exam contains sets of related questions.

A set of questions may contain multiple-choice and/or numerical-response and/or written-response questions.

Tear-out data pages are included near the back of this booklet.

**Note:** *The perforated pages at the back of this booklet may be torn out and used for your rough work. No marks will be given for work done on the tear-out pages.*

### ***Instructions***

- You are expected to provide your own scientific calculator.
- Use only an HB pencil for the machine-scored answer sheet.
- Fill in the information required on the answer sheet and the examination booklet as directed by the presiding examiner.
- Read each question carefully.
- Consider all numbers used in the examination to be the result of a measurement or observation.
- If you wish to change an answer, erase **all** traces of your first answer.
- Do not fold the answer sheet.
- The presiding examiner will collect your answer sheet and examination booklet and send them to Alberta Learning.
- Now turn this page and read the detailed instructions for answering machine-scored and written-response questions.

## Multiple Choice

- Decide which of the choices **best** completes the statement or answers the question.
- Locate that question number on the separate answer sheet provided and fill in the circle that corresponds to your choice.

### Example

This examination is for the subject of

- A. biology
- B. physics
- C. science
- D. chemistry

Answer Sheet



## Numerical Response

- Record your answer on the answer sheet provided by writing it in the boxes and then filling in the corresponding circles.
- If an answer is a value between 0 and 1 (e.g., 0.25), then be sure to record the 0 before the decimal place.
- Enter the first digit of your answer in the left-hand box and leave any unused boxes blank.**

### Examples

#### Calculation Question and Solution

The average of the values 21.0, 25.5, and 24.5 is \_\_\_\_\_.

(Round and record your **answer to one decimal place** in the numerical-response section on the answer sheet.)

$$\begin{aligned} \text{Average} &= (21.0 + 25.5 + 24.5)/3 \\ &= 23.666\dots \\ &= 23.7 \text{ (rounded to one decimal place)} \end{aligned}$$

Record 23.7 on the answer sheet →

•	●		
0	0	0	0
1	1	1	1
●	2	2	2
3	●	3	3
4	4	4	4
5	5	5	5
6	6	6	6
7	7	7	●
8	8	8	8
9	9	9	9

### Correct-Order Question and Solution

When the following subjects are arranged in alphabetical order, the order is \_\_\_\_\_.  
(Record your **four-digit answer** in the numerical-response section on the answer sheet.)

- 1 physics
- 2 chemistry
- 3 biology
- 4 science

Answer 3214

Record 3214 on the answer sheet

3	2	1	4
•	•		
0	0	0	0
1	1	●	1
2	●	2	2
●	3	3	3
4	4	4	●
5	5	5	5
6	6	6	6
7	7	7	7
8	8	8	8
9	9	9	9

### Selection Question and Solution

The birds in the following list are numbered \_\_\_\_\_.  
(Record your answer **in lowest-to-highest numerical order** in the numerical-response section on the answer sheet.)

- 1 dog
- 2 sparrow
- 3 cat
- 4 robin
- 5 chicken

Answer 245

Record 245 on the answer sheet

2	4	5	
•	•		
0	0	0	0
1	1	1	1
●	2	2	2
3	3	3	3
4	●	4	4
5	5	●	5
6	6	6	6
7	7	7	7
8	8	8	8
9	9	9	9

### Written Response

- Write your answers in the examination booklet as neatly as possible.
- For full marks, your answers must address **all** aspects of the question.
- Descriptions and/or explanations of concepts must be correct and include pertinent ideas, diagrams, calculations, and formulas.
- Your answers must be presented in a well-organized manner using complete sentences, correct units, and significant digits where appropriate.
- Relevant scientific, technological, and/or societal concepts and examples must be identified and made explicit.

### Additional Instructions for Students Using Word Processors

- Keep all work together. Diagrams, graphs, calculations, etc. should be placed directly on your word-processed pages.
- Staple your final printed work to the page indicated for each word-processed response.
- Indicate in the space provided on the back cover that you attached word-processed pages.

*Use the following information to answer the first three questions.*

*“It begins in your gut and quickly spreads to your heart and head. Your confidence is swept away with dark foreboding as your heart races and your stomach becomes nauseous.”*

This description was given by a person experiencing a “panic attack” induced by the injection of cholecystokinin (CCK). CCK is a molecule with different functions in different parts of the body. In the brain, it acts as a neurotransmitter that normally regulates memory and recall. It also arouses the emotional and motivational regions of the brain. A gene that encodes CCK has been located.

—from *Hall, 1996*

1. Persons affected by panic attacks appear to be “sensitive” to CCK. This hypothesis would be supported if such persons were found to have
  - A. low levels of CCK
  - B. impaired production of CCK
  - C. CCK inhibitors at these synapses
  - D. excess postsynaptic receptors for CCK
  
2. After mRNA has been produced, the production of CCK is the result of
  - A. translation
  - B. replication
  - C. transcription
  - D. recombination
  
3. Injections of CCK produce responses **similar** to those produced by the stimulation of
  - A. interneurons
  - B. sensory neurons
  - C. sympathetic motor neurons
  - D. parasympathetic motor neurons

*Use the following information to answer the next three questions.*

Two symptoms of Parkinson's disease are lack of muscular coordination and tremors, both caused by inadequate amounts of dopamine. Symptoms of Alzheimer's disease include the deterioration of memory and mental abilities, possibly caused by a decrease in acetylcholine production.

Dopamine and acetylcholine are excitatory neurotransmitters in various parts of the brain.

4. For the neurotransmitters dopamine and acetylcholine, the releasing sites and the receptor sites are, respectively,
- A. cell bodies and dendrites
  - B. dendrites and Schwann cells
  - C. axon terminals and dendrites
  - D. axon terminals and Schwann cells
5. What role do both dopamine and acetylcholine have when they function as excitatory neurotransmitters?
- A. They make the presynaptic membrane more permeable to  $K^+$  ions.
  - B. They make the presynaptic membrane more permeable to  $Na^+$  ions.
  - C. They make the postsynaptic membrane more permeable to  $K^+$  ions.
  - D. They make the postsynaptic membrane more permeable to  $Na^+$  ions.

*Use the following additional information to answer the next question.*

Damage to neurons in different parts of the brain appears to cause Parkinson's and Alzheimer's diseases.

Nerve growth factor (NGF), a chemical produced by peripheral nerves, promotes axon regeneration. Studies show that neurons of the CNS are capable of regeneration when NGF is produced by genetically engineered cells that are transplanted in the CNS.

—from *Greene, 1993*

6. Would it be reasonable to use NGF to regenerate neurons in which nuclei had been destroyed?
- A. Yes, because not all cells require a nucleus to function
  - B. Yes, because organelles other than the nucleus cause growth
  - C. No, because the nucleus controls protein synthesis and homeostasis
  - D. No, because without the nucleus to actively transport ions, the cell would die

7. Which of the following situations illustrates that simple reflexes can be controlled through learned behaviour or conscious effort?
- A. A student cries “ouch” after pulling his hand away from a sharp pin.
  - B. A knee jerk occurs when the patellar ligament below the kneecap is tapped.
  - C. While clenching a textbook against his chest, a student has an exaggerated knee jerk.
  - D. Even though she is burned, a mother does not drop a pot of boiling water when her child is standing at her side.

*Use the following information to answer the next question.*

<b>Age and Eye Accommodation</b>	
<u>Age in Years</u>	<u>Near Point Accommodation*</u> (cm)
10	7.5
20	10.0
30	11.5
40	17.2
50	65.9
60	90.0

\*The shortest distance between the eye and an object where focus of the object is achieved.

—from *Schmidt and Thews, 1983*

8. After studying the data, a student stated, “From age 10 to age 60, the eye has an ever-increasing ability to focus on nearby objects.” This statement represents
- A. a restatement of the data
  - B. a theory supported by the data
  - C. an interpretation supported by the data
  - D. an interpretation contradicted by the data

*Use the following information to answer the next question.*

The graph below illustrates the effects of different temperatures on the responses of four different nerve fibres in the skin.

**Unfortunately, it is not possible to gain permission for electronic publication of all the source material for this question.**

9. Which of the following statements presents a valid interpretation of the information on the graph?
- A. A temperature of 5°C is less painful than a temperature of 50°C.
  - B. A sensation of coolness is interpreted only when two types of receptors are stimulated.
  - C. The threshold level of stimulation is higher for temperature receptors than it is for pain receptors.
  - D. Temperature sensations are determined by the number of impulses per second and the specific type of receptors.



*Use the following information to answer the next three questions.*

Mercury poisoning causes neurological damage, which leads to a deterioration of short-term memory and an inability to coordinate muscle movements.

10. The areas of the brain affected by mercury poisoning as indicated by the above symptoms are, respectively, the
- A. cerebrum and medulla
  - B. cerebellum and cerebrum
  - C. cerebrum and cerebellum
  - D. hypothalamus and cerebellum

*Use the following additional information to answer the next question.*

Mercury poisoning also affects the pituitary gland in such a way that frequent urination results.

11. Mercury compounds **most likely** affect the level of the hormone
- A. LH
  - B. FSH
  - C. ADH
  - D. ACTH

*Use the following additional information to answer the next question.*

Certain mercury compounds are able to cross the placenta and thereby affect embryological development.

—from *Hedegard, 1993*

12. Exposure to mercury compounds during embryological development would **most likely** disrupt the
- A. production of amniotic fluid
  - B. development of the neural tube
  - C. production of ovarian hormones
  - D. development of the umbilical cord

*Use the following information to answer the next question.*

For hundreds of years, Chinese folk doctors have known an intriguing but mysterious fact. Drinking herbal tea brewed with a type of club moss (*Huperzia serrata*) can improve a person's memory.

About ten years ago, researchers at the Shanghai Institute of Materia Medica isolated a compound from the tea that is a strong inhibitor of cholinesterase. The compound, called huperzine A, and its effect on acetylcholine are the subjects of intense research. Researchers hope to use huperzine A as an over-the-counter drug and as a potential medication for Alzheimer's disease.

—from *Cheng, Ren, and Tang, 1996*

13. If huperzine A were present in synapses between motor neurons and muscles, it would
- A. prevent the breakdown of acetylcholine
  - B. prevent the contraction of skeletal muscles
  - C. cause the release of sodium ions from axon terminals
  - D. cause the secretion of acetylcholine from axon terminals
- 

*Use the following information to answer the next three questions.*

During stressful experiences, interactions between the nervous and endocrine systems prepare the body to defend itself or to handle injury.

14. Which hormone is released as a direct result of sympathetic motor neuron stimulation?
- A. HGH
  - B. Thyroxine
  - C. Aldosterone
  - D. Epinephrine

Use the following additional information to answer the next two questions.

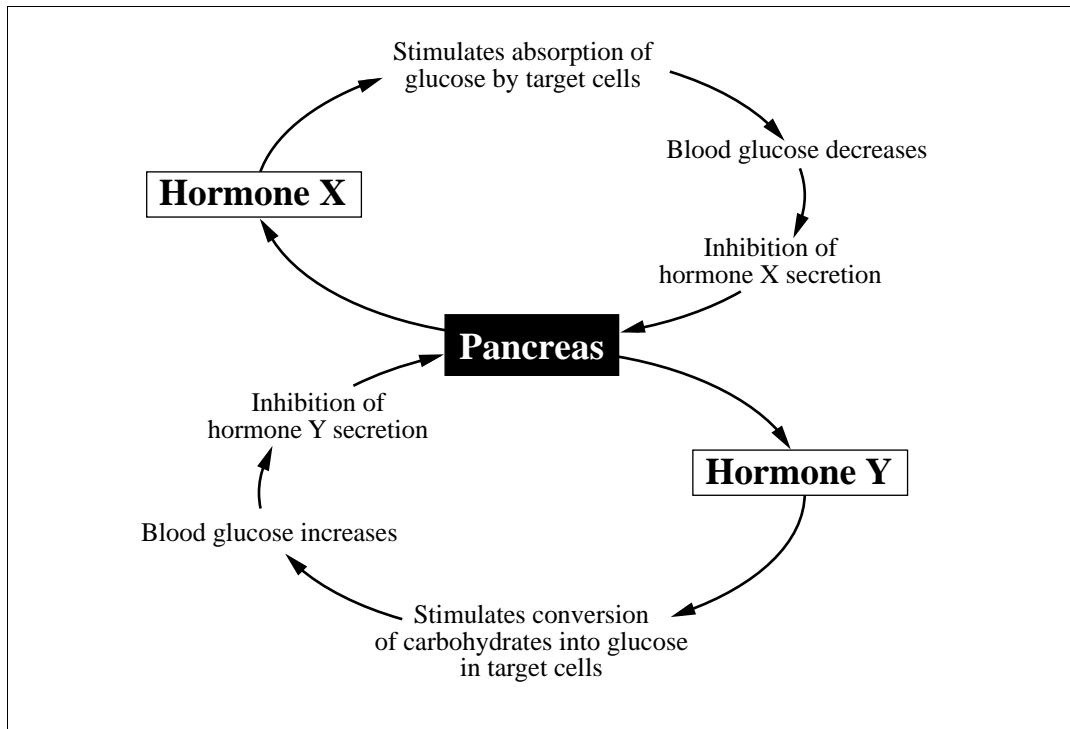

15. If blood glucose levels change, the pancreas will
- A. stop hormone secretions because the target cells are not working
  - B. produce a more active form of the hormone that stimulates the target cells
  - C. cause other endocrine glands to secrete hormones that stimulate the target cells
  - D. increase the secretion of the appropriate hormone that stimulates the target cells
16. The names of hormones X and Y are, respectively,
- A. insulin and glucagon
  - B. glucagon and insulin
  - C. glycogen and insulin
  - D. insulin and glycogen

*Use the following information to answer the next question.*

In male and female embryos, the development of the genital ridge influences gender determination. The male and female genotypes (sex chromosomes) differ in that they cause the release of different hormones from the genital ridge in males and females during development.

17. Which of the following statements about normal embryonic hormone secretion is correct?
- A. The X chromosome secretes estrogen in a female embryo.
  - B. The Y chromosome secretes testosterone in a male embryo.
  - C. The genital ridge produces estrogen in a potential female embryo.
  - D. The genital ridge produces testosterone in a potential female embryo.
- 
18. The development of secondary sexual characteristics in the female is due to the secretion of
- A. LH, followed by the secretion of estrogen
  - B. LH, followed by the secretion of progesterone
  - C. FSH and LH, followed by the secretion of estrogen
  - D. FSH and LH, followed by the secretion of progesterone
19. The hormone that stimulates sex-cell production in both males and females is
- A. LH
  - B. FSH
  - C. testosterone
  - D. progesterone
20. Which area of the brain regulates male or female reproductive behaviour by directly controlling the release of gonadotropins from the pituitary gland?
- A. Hypothalamus
  - B. Pituitary gland
  - C. Medulla oblongata
  - D. Frontal lobe of the cerebrum

Use the following information to answer the next two questions.

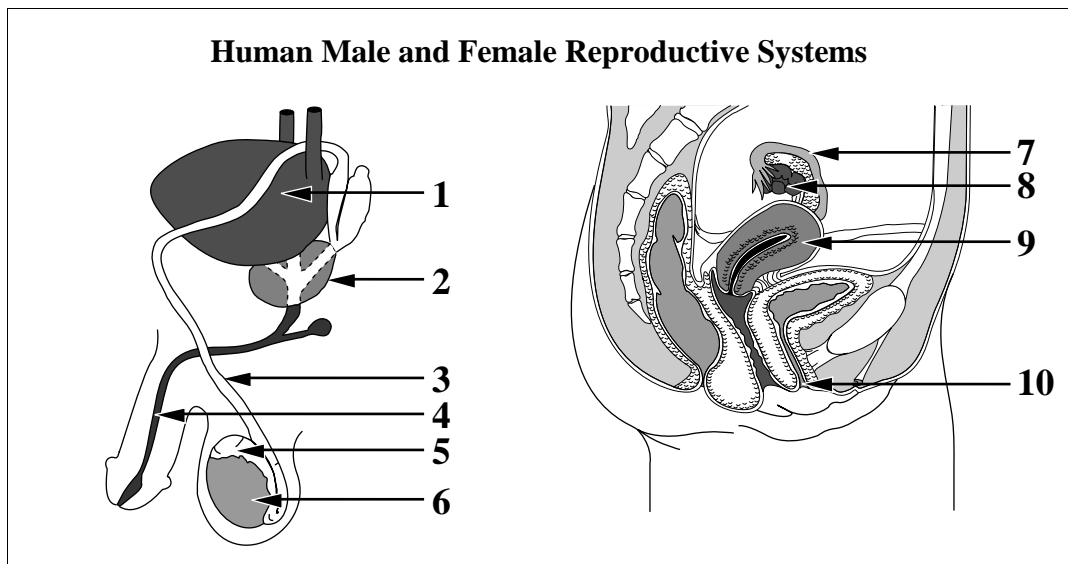

21. Meiosis occurs in which male and female structures, respectively?
- A. 6 and 9
  - B. 6 and 8
  - C. 5 and 9
  - D. 5 and 8
22. Reproductive structures that have similar functions in males and females are, respectively,
- A. 4 and 10
  - B. 3 and 7
  - C. 2 and 8
  - D. 1 and 9
- 
23. Collectively, the seminal vesicles, prostate gland, and Cowper's glands contribute to which of the following functions?
- A. Produce testosterone
  - B. Stimulate spermatogenesis
  - C. Help sperm survive in the female body
  - D. Signal the pituitary to release gonadotropins

24. Hormones that stimulate the production of testosterone are transported by the
- A. blood
  - B. vas deferens
  - C. seminiferous tubules
  - D. ducts from the gland secreting the hormones

*Use the following information to answer the next question.*

In rare cases, human males develop functioning mammary glands. Hormone levels are known to affect the development and function of mammary glands in both males and females.

25. For human males to produce milk and to eject milk, high levels of which two hormones, respectively, must be present?
- A. Prolactin and relaxin
  - B. Relaxin and prolactin
  - C. Prolactin and oxytocin
  - D. Oxytocin and prolactin

*Use the following information to answer the next question.*

William Hunter was born without vas deferens. Despite surgery and attempts at artificial insemination and conventional *in vitro* fertilization, William and his wife were unable to conceive.

—from *Shirk, 1994*

26. A new technology that may help William involves sperm extraction followed by sperm injection to produce a fertilized egg. This technology must involve
- A. LH therapy
  - B. testosterone therapy
  - C. extraction of sperm from the male's urethra
  - D. extraction of sperm from the male's epididymis

Use the following information to answer the next question.

**Reproductive Events in a Mature Human Female**

- 1 Ovulation
- 2 Placenta forms
- 3 Fertilization
- 4 Implantation

**Numerical Response**

- 1.** The above events, in the sequence in which they occur before childbirth, are \_\_\_\_\_.

(Record your **four-digit answer** in the numerical-response section on the answer sheet.)

**Answer:** \_\_\_\_\_  
\_\_\_\_\_

Use the following information to answer the next question.

**Some Events in the Human Reproductive Cycle**

- 1 Pre-embryo releases HCG, which maintains hormone levels
- 2 A hormone signals the follicle to rupture
- 3 Blastocyst is implanted
- 4 The egg is fertilized to form a zygote.

**Numerical Response**

- 2.** The above events, in the sequence in which they occur during the reproductive cycle, are \_\_\_\_\_.

(Record your **four-digit answer** in the numerical-response section on the answer sheet.)

**Answer:** \_\_\_\_\_  
\_\_\_\_\_

Use the following information to answer the next question.

The genital tract of both females and males can play host to many disease-causing microbes. The sexually transmitted diseases (STDs) that can result include gonorrhea, syphilis, herpes, AIDS, genital warts, and chlamydia. These diseases, if untreated, may lead to brain and nervous system deterioration, circulatory system damage, cancer, and infertility. Microbes may pass from mother to child during pregnancy and birth.

27. STD microbes may be transmitted to the
- A. child in the vagina
  - B. zygote in the endometrium
  - C. embryo by the ingestion of amniotic fluid
  - D. fetus by the entry of blood from the uterine veins

Use the following information to answer the next question.

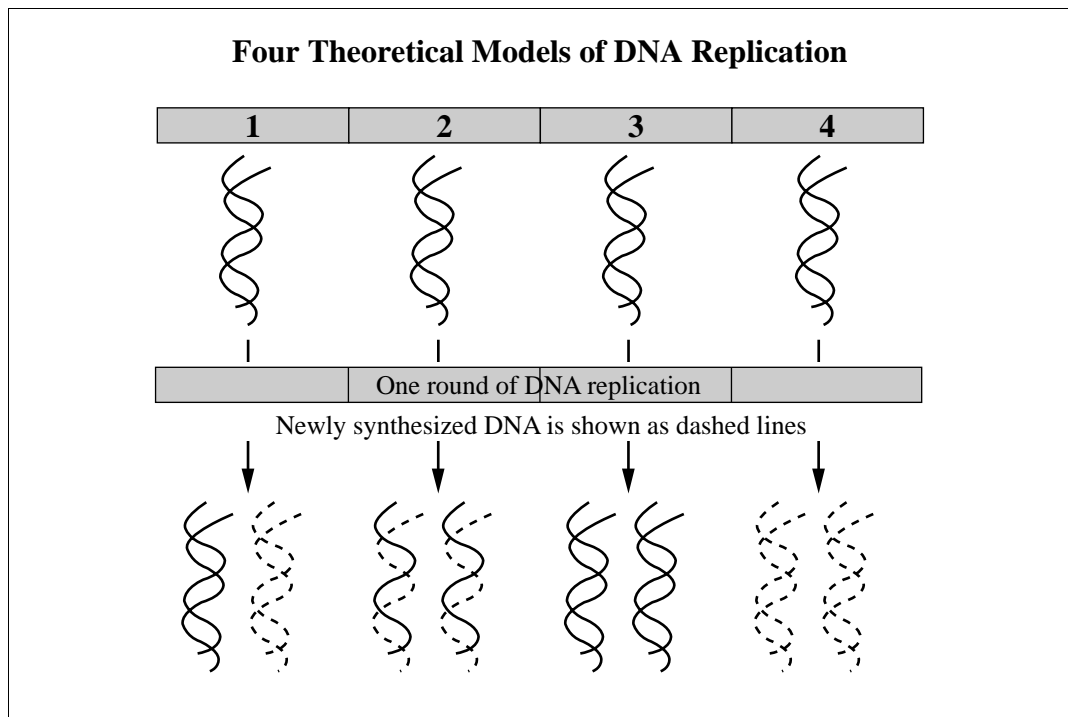

28. Which number represents the model of DNA replication that occurs in human cells?
- A. 1
  - B. 2
  - C. 3
  - D. 4



*Use the following information to answer the next question.*

**Unfortunately, it is not possible to gain permission for electronic publication of all the source material for this question.**

**Numerical Response**

- 3.** Match the stages of the mitotic phase, as numbered above, with the appropriate stage of mitosis given below.

(Record your **four-digit answer** in the numerical-response section on the answer sheet.)

**Mitotic Phase:** \_\_\_\_\_  
**Stage of Mitosis:** **Anaphase**   **Metaphase**   **Prophase**   **Telophase**

Use the following information to answer the next question.

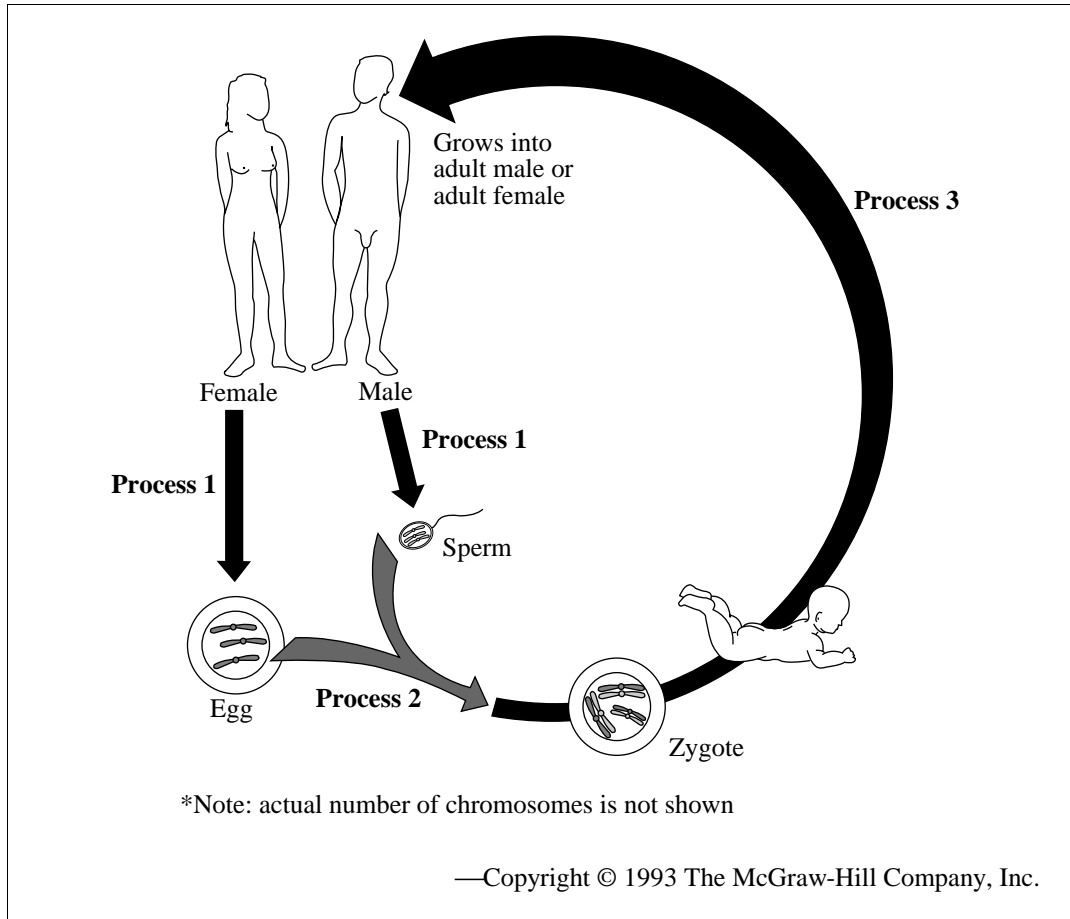

**Numerical Response**

4. Identify the processes, as labelled in the diagram above, that represent the activities given below.

(Record your **three-digit answer** in the numerical-response section on the answer sheet.)

<b>Process:</b>	_____	_____	_____
<b>Activity:</b>	Division of diploid cells to produce diploid cells	Haploid cells combine to form a diploid cell	Division of diploid cells to produce haploid cells

Use the following information to answer the next two questions.

Scientists believe that a mutant form of an autosomal gene called BRCA<sub>1</sub> may be associated with 5% to 10% of all cases of breast cancer. About 80% of women who inherit the gene in its defective form are likely to develop a cancerous breast tumour. Men who carry the faulty BRCA<sub>1</sub> gene rarely develop breast cancer, but they may pass the gene to their offspring.

A couple have two children, a girl and a boy. The mother has a single mutant gene for breast cancer; the father is not a carrier of the mutant BRCA<sub>1</sub> gene.

—from Richards, 1996

29. What is the probability that their daughter has inherited the mutant BRCA<sub>1</sub> gene?

- A. 75%
- B. 50%
- C. 25%
- D. 0%

Use the following additional information to answer the next question.

There is some evidence that two genes, BRCA<sub>1</sub> and BARD<sub>1</sub>, suppress certain types of cancer. If either of these genes is defective, ovarian and/or breast tumours may develop. The mutant form of BARD<sub>1</sub> is considered to be recessive.

Studies have shown that the proteins encoded by the BRCA<sub>1</sub> and BARD<sub>1</sub> genes differ from one another, but that they probably link up. In doing so, they somehow prevent tumour growth. The abnormal genes may result in the production of faulty proteins that will not link.

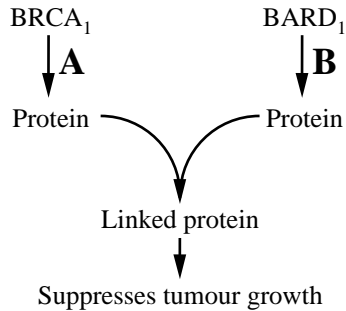

—from Carney, Futreal, and Lancaster, 1997

30. Four individuals undergo carrier screening for the two genes, and the following results are observed. Which of the following individuals is **most likely** to develop ovarian and/or breast tumours?

Row		BRCA <sub>1</sub>	BARD <sub>1</sub>
A	Individual 1	heterozygous	homozygous dominant
B	Individual 2	heterozygous	heterozygous
C	Individual 3	homozygous normal	homozygous normal
D	Individual 4	heterozygous	homozygous recessive

*Use the following information to answer the next question.*

Compared with premenopausal women, women entering menopause have increased levels of FSH and LH. These women can choose to undergo estrogen and/or progesterone hormone replacement therapy to alleviate the symptoms of menopause.

31. If a menopausal woman takes hormone replacement therapy, the levels of her FSH and LH will
- A. not be affected because her ovaries no longer respond to estrogen
  - B. cause the ovary to produce eggs, and the woman will again be fertile
  - C. drop because of the negative-feedback effect of progesterone and estrogen
  - D. rise as estrogen and progesterone levels stimulate the production of FSH and LH
- 

*Use the following information to answer the next two questions.*

Melanin pigments range in colour from yellow to reddish-brown to black. The amount and the colour of melanin in the skin account for differences in human skin coloration.

Albinism is a genetic disorder that results in unpigmented skin and other tissues. About 1 in 20 000 humans has albinism. In humans, it can be caused by an autosomal recessive allele (*a*). Its dominant allele (*A*) results in normal pigmentation.

32. The fact that exposure to sunlight increases melanin production in many humans and produces a tan demonstrates that
- A. some people have mutations that prevent melanin production
  - B. the expression of some genes is influenced by the environment
  - C. the environment causes mutations that increase the chance of survival
  - D. the environment causes mutations that have no effect on the chance of survival
33. In the type of albinism described above, because melanin production is controlled by an autosomal gene, it is expected that
- A. males will develop albinism as they mature
  - B. males will inherit albinism from their mothers
  - C. albinism will occur more frequently among males than females
  - D. albinism will occur with equal frequencies among males and females

Use the following information to answer the next question.

Piebald spotting is a rare human disorder. Although this disorder occurs in all races, piebald spotting is most obvious in people with dark skin. A dominant allele appears to interfere with the migration of pigment-producing cells; thus, patches of skin and hair lack pigment, allowing “spots” to form.

**Pedigree Chart for Piebald Spotting**

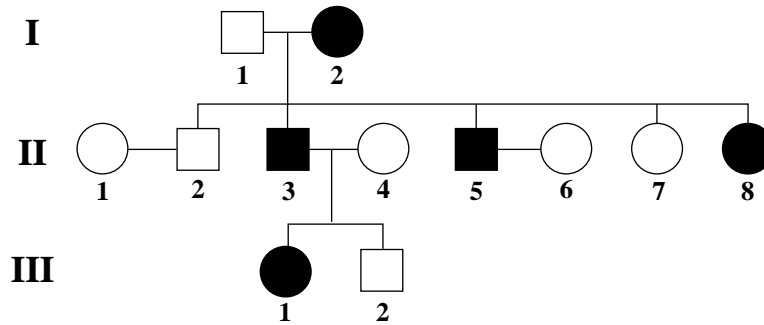

**Numerical Response**

5. What is the probability that any offspring produced by individuals II-5 and II-6 would have piebald spotting?

(Record your answer as a value from 0 to 1 rounded to two decimal places in the numerical-response section on the answer sheet.)

Answer: \_\_\_\_\_

Use the following information to answer the next question.

In garden peas, the allele for tall plant height ( $T$ ) is dominant over the allele for short plant height ( $t$ ), and the allele for axial flower position ( $A$ ) is dominant over the allele for terminal flower position ( $a$ ). The alleles for plant height and flower position assort independently.

34. A plant heterozygous for both traits was crossed with a plant homozygous recessive for both traits. What percentage of the offspring produced would be expected to display at least one of the dominant traits?
- A. 25%
  - B. 50%
  - C. 75%
  - D. 100%

Use the following information to answer the next question.

“Alligator men” or “fish women” were exhibited for their physical abnormalities in fairs or circuses earlier this century. These people probably suffered from X-linked ichthyosis, which produces symmetric dark scales on the body. The disease occurs in 1 in 6 000 males and much more rarely in females. Ichthyosis is likely a recessive disorder.

—from *Cummings, 1994*

### Numerical Response

6. If an “alligator man” were to marry a woman homozygous for the normal condition, what is the **percentage** probability that their children would have ichthyosis?

(Record your **answer as a whole number percentage** in the numerical-response section on the answer sheet.)

Answer: \_\_\_\_\_ %

Use the following information to answer the next question.

### F<sub>1</sub> Blood Type Cross

$I^A I^B$	$I^A i$
$I^A I^B$	$I^A i$

35. The genotypes of the parents to whom this Punnett square applies are
- A. heterozygous B and homozygous A
  - B. heterozygous O and homozygous A
  - C. homozygous B and heterozygous A
  - D. heterozygous B and heterozygous A

Use the following information to answer the next question.

### A, B, M, N, O, and Rh Blood Typing

The alleles for A( $I^A$ ) and B( $I^B$ ) are codominant, and both are dominant to O( $i$ ).

The alleles for M and N are codominant.

The allele for  $Rh^+$  is dominant to the allele for  $Rh^-$ .

Blood groups can be used to determine relationships for a variety of legal and medical purposes. The following is a list of phenotypes of some children over whom there is a legal dispute.

	Blood Types		
Child 1	O	MN	$Rh^+$
Child 2	A	N	$Rh^+$
Child 3	A	MN	$Rh^-$
Child 4	AB	MN	$Rh^-$

36. Which children could belong to a couple in which the woman has blood type A, N,  $Rh^+$  and the man has blood type O, M,  $Rh^+$ ?
- A. Children 1 and 3
  - B. Children 1 and 4
  - C. Children 2 and 3
  - D. Children 2 and 4

Use the following information to answer the next question.

A program to detect carriers of  $\beta$ -thalassemia (a mild blood disorder) found the incidence of the disease to be 4% in a particular population. A recessive allele found on an autosomal chromosome causes  $\beta$ -thalassemia.

### Numerical Response

7. What is the frequency of the recessive  $\beta$ -thalassemia allele in the gene pool of this population?

(Record your answer as a value from 0 to 1 rounded to one decimal place in the numerical-response section on the answer sheet.)

Answer: \_\_\_\_\_

Use the following information to answer the next four questions.

Sickle cell anemia is caused by the sickle cell allele ( $Hb^S$ ) of a gene that contributes to hemoglobin ( $Hb$ ) production. The abnormal hemoglobin (hemoglobin-S) produced causes red blood cells to become deformed and block capillaries. Tissue damage results. Affected individuals homozygous for the sickle cell gene rarely survive to reproductive age. Heterozygous individuals produce both normal hemoglobin and a small percentage of hemoglobin-S. These individuals are more resistant to malaria than individuals who are homozygous for the allele for normal hemoglobin ( $Hb^A$ ). Their red blood cells are prone to sickling when there is a deficiency of oxygen.

37. If a man and a woman who are both heterozygous for the alleles  $Hb^A$  and  $Hb^S$  have a child, the probability that the child would **not** be heterozygous is
- A. 0.00
  - B. 0.25
  - C. 0.50
  - D. 0.75

Use the following additional information to answer the next question.

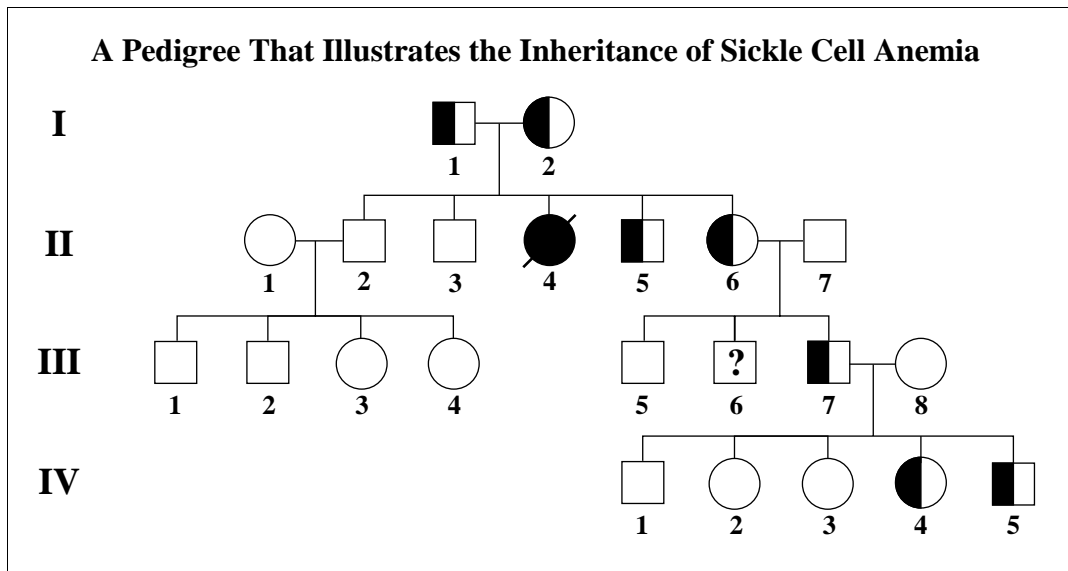

**Numerical Response**

8. The phenotype of III-6 is unknown. What is the probability that this individual is a carrier of the sickle cell allele?

(Record your answer as a whole number percentage in the numerical-response section on the answer sheet.)

Answer: \_\_\_\_\_ %



Use this additional information to answer the next two questions.

The malaria-causing microorganism *Plasmodium falciparum* is injected by mosquitoes into the bloodstream of humans. Historically, the frequency of the  $Hb^S$  allele in Africa relates directly to the presence of malaria-causing organisms. In western Africa, the frequency of the  $Hb^S$  allele in the gene pool is 0.15. In central Africa, the frequency is 0.10, and in southern Africa the frequency is 0.05.

38. What is the frequency of the  $Hb^A$  allele in the human gene pool in western Africa?
- A. 0.72
  - B. 0.85
  - C. 0.90
  - D. 0.95
39. Which of the following conclusions can be drawn from all the information provided on sickle cell anemia?
- A. The sickle cell gene will eventually disappear because of its interaction with malaria.
  - B. Malaria causes heterozygous individuals to be less fertile than homozygous individuals.
  - C. In Africa, sickle cell anemia will disappear since it is lethal in the homozygous condition.
  - D. In Africa, carriers for sickle cell anemia have an advantage over homozygous individuals.

*Use the following information to answer the next question.*

A bacterium has been found that produces a form of plastic called polyhydroxybutyrate (PHB). Genes from this bacterium have been transferred into a weed called *Arabidopsis thaliana*. These weeds now produce a biodegradable plastic.

—from Poirier, et al., 1997

40. The technology of transferring a gene from a bacterium into a green plant is based on the principle that
- A. all genes carry the same genetic information
  - B. all genes have the same basic chemical components
  - C. the genotypes of the bacterium and green plant are the same
  - D. the phenotype of an organism is not altered when one gene is exchanged for another
- 

*Use the following information to answer the next question.*

A swimming pool 50 m long and 20 m wide is filled with water to a depth of 3 m. The population density of bacteria in the water is  $2.5 \times 10^6$  bacteria/m<sup>3</sup>.

41. Approximately how many bacteria are there in the swimming pool?
- A.  $2.5 \times 10^9$
  - B.  $7.5 \times 10^9$
  - C.  $2.5 \times 10^{12}$
  - D.  $7.5 \times 10^{12}$

*Use the following information to answer the next question.*

Weeds, insect pests, and disease result in a loss of about 45% of the world's food supply annually. The use of insecticides and herbicides reduces the loss of food supply.

- 42.** The most serious drawback of using chemicals to control pests is that most pest populations, especially insects, develop genetic resistance to chemicals. How do insect populations develop this resistance and pass it to offspring?
- A.** Mutations and natural selection give some insects an advantage, and eventually gene frequencies change until most have the trait.
  - B.** Through use of restriction enzymes and ligases, new sequences of DNA are created and passed to offspring.
  - C.** The pesticides cause the synthesis of new proteins with altered amino acid sequences.
  - D.** The offspring of insects that learned to avoid the spray also learn to avoid the spray.
- 
- 43.** When limited food supplies have threatened to check human population growth, people have used technology and social organization to clear forests, plow grasslands, grow crops, and harness science to agriculture. This indicates that food is
- A.** a biotic factor that humans can manipulate
  - B.** an abiotic factor that humans can manipulate
  - C.** a biotic factor that humans cannot manipulate
  - D.** an abiotic factor that humans cannot manipulate

Use the following information to answer the next three questions.

People living in certain tropical countries are at risk of becoming infected by guinea worms. An adult female worm lives under the skin in the human body where it grows up to 90 cm in length. An infected person shows no symptoms until the worm comes to the surface to release its larvae. When it emerges, the worm releases a toxin that causes a painful, burning blister that is relieved by immersion in cool water. When the blister is submerged, the worm releases its young. Over several weeks, the adult worm works its way out of the body. During that time, infected people suffer and cannot work or go to school.

People can be infected by drinking water that is contaminated by water fleas, the small aquatic animals in which the worm completes other parts of its life cycle.



These photographs illustrate how the guinea worm is removed from the foot of an infected person.  
—photographs from [www.travelhealth.com/tropdz/dracpage.htm](http://www.travelhealth.com/tropdz/dracpage.htm)

#### Eradication Success in an African Village

The African village of Kati has a population of about 3 000 people. At the end of 1981, the village began a health education program about guinea worms. In 1984, new water wells were dug in the village. The chart at the right shows the number of people infected with guinea worms from 1981 to 1990.

<u>Year</u>	<u>Number of Cases of Infection</u>
1981	928
1982	535
1983	263
1984	125
1985	7
1986	2
1987	5
1988	0
1989	0
1990	0

—adapted from *Nuttall, 1995*

44. Total elimination of the water fleas in places where guinea worms are a problem would result in
- A. more infected people since the larvae would now infect people directly
  - B. fewer infected people since the guinea worm's life cycle would be broken
  - C. more infected people because the guinea worm's life cycle would be shorter
  - D. fewer infected people because there would be no way for the larvae to enter the water

45. Which of the following rows **best** illustrates the relationship of guinea worms to both humans and water fleas?

Row	Guinea worm	Human	Water flea
A	parasite	host	host
B	parasite	host	prey
C	predator	prey	prey
D	predator	prey	host

46. A correct interpretation of the data collected in Kati is that the problem of guinea worm infection
- A. has been eliminated in African countries either through public education programs or by providing clean well-water
  - B. has been eliminated in African countries by providing educational programs and supplies of clean drinking water
  - C. could be eliminated either through public education programs or by providing clean well-water
  - D. could be eliminated by providing educational programs and sources of clean drinking water



The Aesculapian staff, symbol of the medical profession, might be the guinea worm on a stick.

—from *Haeger, 1988*

47. Which of the following relationships would be considered to be a mutualistic relationship?
- A. The myxoma virus was introduced to control the rabbit population in Australia.
  - B. The abandoned burrows of woodpeckers often become nesting sites for bluebirds.
  - C. Blowfly eggs, laid on the skin of sheep, develop into larvae that feed on sheep tissues.
  - D. The stomachs of cattle contain large populations of bacteria that aid in the digestion of cellulose.

Use the following information to answer the next question.

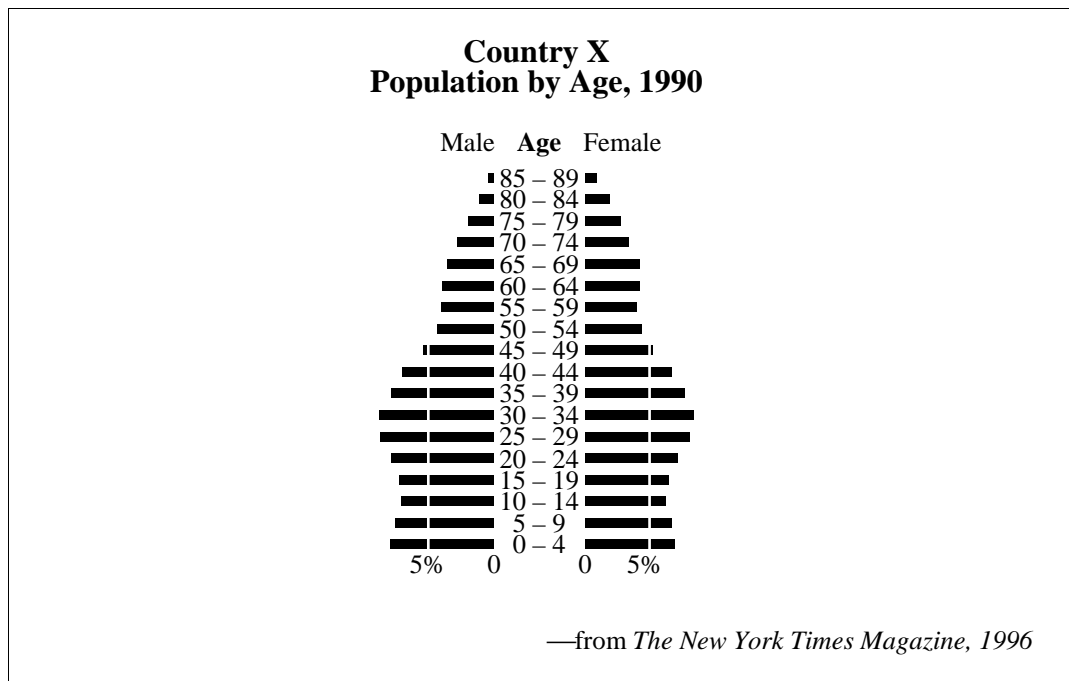

48. According to the above data, in which decade would the cost of health care for seniors (age 65 and over) create the greatest governmental concern?
- A. 1990–2000
  - B. 2000–2010
  - C. 2020–2030
  - D. 2040–2050

*Use the following information to answer the next question.*

On April 26, 1986, one of the worst technological, industrial, and environmental disasters known to humankind occurred. A nuclear reactor in Chernobyl exploded and showered radioactive debris over much of Eastern Europe. The extent of the environmental and health effects of the nuclear legacy of Chernobyl are still unknown.

Although the exact causes of many illnesses are not understood, there is little doubt that the enormous burst of radiation released from the reactor has had devastating effects on thousands of children. One of the most dangerous radioactive products released was iodine-131. It was inhaled by many children, exposing them to high levels of radiation. Iodine-131 was absorbed by the children's thyroid glands, causing inflammation of the gland and an increased incidence of thyroid cancer. Normally, iodine is absorbed from the blood by the thyroid gland in its synthesis of thyroxine.

The effects of this radiation over a long period of time were also studied. Researchers looked at DNA gene sequences five to 45 bases long from blood samples taken from parents and their children born in 1994 or later. They looked for any sequence in the child's DNA that did not occur in the blood cells of either parent. The children born near Chernobyl had twice as many of these mutations in their DNA as had the control group, which consisted of families in England whose children were also born in or after 1994.

—from *Monmaney, 1996*  
*Shcherbak, 1996*

**Written Response – 15%**

Staple your word-processed response for **this** question to this page.

- 1.** a. Explain one function of thyroxine. **(1 mark)**

- b. Draw a feedback loop that illustrates the regulation of the release of thyroxine. Include relevant glands and hormones. **(3 marks)**
- c. Thyroid cancer in infants can be treated by surgical removal of the thyroid gland. Identify **two** signs and/or symptoms that would indicate or would be caused by the absence of thyroxine in such an infant. **(2 marks)**
- d. The children exposed to radioactive iodine because of the nuclear accident were treated with high levels of non-radioactive iodine. Explain why this treatment was used. **(1 mark)**



- e. Describe and sketch one type of error at the molecular level of DNA that results in a mutation. (Create a hypothetical strand of DNA bases, then show the strand again, illustrating and clearly marking the change causing the error.) **(3 marks)**

- f. The evidence presented in the last paragraph of the reading suggests that mutations occurred in one of the parents' germ-line cells (precursor cells to oocytes or sperm cells). Describe how the germ-line cell mutations appeared in the children's white blood cells. **(2 marks)**

*Use the following information to answer the next question.*

There is a worldwide shortage of organs for transplanting into humans. Some researchers are concentrating on xenotransplantation—using organs from other species—as a solution.

The pig is considered by researchers as the most suitable donor of transplant organs for humans, even though pigs are not as closely related genetically to humans as higher primates are. Pigs can be bred easily and up to three times a year. Sows have short pregnancies (about 115 days) and give birth to large litters. The offspring grow quickly to reach a large size.

Transplanted organs from ordinary pigs are quickly rejected by the human immune system. Researchers have isolated a human gene, called HDAF, that codes for a cell membrane protein known as RCA. The human HDAF gene can be inserted into pig DNA so the human RCA protein will be present on the surface of pig cells. Human RCA protein on cell membranes of pig cells is expected to inhibit the rejection of pig organs when they are transplanted into humans. A pig that has the human gene in all of its cells is referred to as a transgenic pig.

Fertilized eggs are harvested from a sow

Injection of HDAF gene into the nuclei of the fertilized eggs

Transfer of injected eggs into recipient sows

**Unfortunately, it is not possible to gain permission for electronic publication of all the source material for this question.**

Identification of heterozygote transgenic offspring (shaded grey) expressing RCA protein in their organs

Identification of homozygote transgenic offspring (shaded dark grey) expressing RCA protein in their organs

**Written Response – 15%**

Staple your word-processed response for **this** question to this page.

2. Write a unified response that addresses the following aspects of the use of pigs as a source of organs for transplantation.

- **Compare** the biotic potential of pig populations with that of other mammals, such as primates or humans. **Explain** how two traits of pigs would have influenced researchers to choose pigs as the most suitable animals for xenotransplantation.
  
- **Describe** one technology that researchers would have used to obtain the HDAF gene. **Explain**, in detail, what happens after the HDAF gene is injected into fertilized eggs to produce heterozygote transgenic offspring and normal offspring.
  
- **Explain** why researchers performed crosses of heterozygote offspring and **explain** the observed outcome of these crosses using a Punnett Square to clarify your explanation.

.....

.....

.....

.....

.....

.....

.....

.....

.....

.....

.....

.....

.....

.....

.....

.....

.....

.....

.....

.....

.....

.....

.....

.....

A series of 25 horizontal dotted lines spanning the width of the page, intended for writing or drawing.



## References

- MC1 Hall, J. 1996. Pinpointing people's panic buttons. *The Edmonton Journal*. 9 January.
- MC6 Greene, M. 1993. Spinal cord research: Making nerves grow. *Today's Science on File*. January 1993: 82.
- MC8 Schmidt, F. and G. Thews. 1983. *Human Physiology*. New York: Springer-Verlag.
- MC12 Hedegard, L. 1993. Amalgam-related illness FAQ. *Handbook for Victims of Mercury-Poisoning from Dental Amalgam*. November.
- MC13 Cheng, D.H., H. Ren, and X.R. Tang. 1996. Huperzine A, a novel promising acetylcholinesterase inhibitor. *Neuroreport* 8(1): 97-101.
- MC26 Shirk, M. 1994. U.S., Belgian doctors pioneer method to cure male infertility. *Winnipeg Free Press*. 11 July.
- MC29 Richards, M. 1996. Genetics and health. *Biological Sciences Review*. November: 26-29.
- MC30 Carney, M., A. Futreal, and J. Lancaster. "BRCA1 and 2—A genetic link to familial breast and ovarian cancer." <http://www.medscape.com/Medscape/womens.health/1997/v02.n02/w134.lancaster/w134.lancaster.html>
- NR6 Cummings, M. 1994. *Human Heredity*. St. Paul: West Publishing Company.
- MC40 Poirier, Y. et al. 1997. "Polyhydroxybutyrate, a biodegradable thermoplastic, produced in transgenic plants." <http://nightshade.cit.cornell.edu/coursepak/poirier.htm>
- MC44 Nuttall, I. 1995. "Disease sheet: Dracunculiasis (Action)." <http://www.who.ch/programmes/ctd/diseases/drac/dracact.htm>
- WR1 Monmaney, T. 1996. Chernobyl's legacy: The stuff of science fiction. *The Edmonton Journal*. 5 May.
- Shcherbak, Y. 1996. Ten years of the Chornobyl Era. *Scientific American*. April: 44-49.
- WR2 Lanza, R., D. Cooper, and W. Chick. 1997. Xenotransplantation. *Scientific American*. July: 54-59.
- Cozzi, E. and D. White. 1996. Transgenic pigs—human organ factories? *Biological Sciences Review*. November: 23-25.

## Illustration Credits

- MC9 Graph from *Textbook of Medical Physiology* by A.C. Guyton and J.E. Hall, (W.B. Saunders Company, 1996). Reprinted with permission of W.B. Saunders Company.
- NR3 Diagram from *Biology* by Neil Campbell; Copyright (©) 1987 by The Benjamin/Cummings Publishing Company. Reprinted by permission.
- NR 4 Diagram from *Understanding Biology* by P.H. Raven and G.B. Johnson, (Mosby-Year Book, 1991). Reprinted with permission of The McGraw-Hill Companies.
- MC44 Photographs © the United States Armed Forces Institute of Pathology. Public Domain.
- MC46 Emblem from *The Illustrated History of Surgery* by K. Haeger, (Bell Publishing Company, 1988). Public Domain.
- MC48 Graph from *The New York Times Magazine*, September 29, 1996. Reprinted by permission of New York Times Graphics.
- WR2 Figure adapted from *Biological Sciences Review* by E. Cozzi and D. White, Philip Allan (1996) U.K. Reprinted by permission of Philip Allan Publishers.
- Photograph from *Doctoring a pig's genes* by J. Tobin. Reprinted with permission of The Detroit News.

## BIOLOGY DATA

## Symbols

Symbol	Description
$D_p$	population density
$N$	numbers of individuals in a population
$A$	area, space, or volume occupied by a population
$t$	time
$\Delta$	change
$r$	biotic potential OR maximum per capita population growth rate
$K$	carrying capacity
$\frac{\Delta N}{\Delta t}$	a change in population size during time interval
$>$	greater than, dominant over
$<$	less than, recessive to

Symbol	Description
♂	male
♀	female
$n$	chromosome number
$B, b$	alleles; upper case is dominant, lower case is recessive
$I^A, I^B, i$	alleles, human blood type (ABO)
$P$	parent generation
$F_1, F_2$	first, second filial (generation)
$p$	frequency of dominant allele
$q$	frequency of recessive allele

## Equations

Subject	Equation
Hardy-Weinberg principle	$p^2 + 2pq + q^2 = 1$
Population density	$D_p = \frac{N}{A}$
Change in population size	$\Delta N = (\text{factors that increase pop.}) - (\text{factors that decrease pop.})$
Per capita growth rate (time will be determined by the question)	$cgr = \frac{\Delta N}{N}$
Growth rate	$\frac{\Delta N}{\Delta t} = rN$ $\frac{\Delta N}{\Delta t} = rN \frac{(K - N)}{K}$

Fold and tear along perforation.

### Abbreviations for Some Hormones

Hormone	Abbreviation
Adrenocorticotropin hormone	ACTH
Antidiuretic hormone	ADH
Follicle stimulating hormone	FSH
Human chorionic gonadotropin	HCG
Luteinizing hormone	LH (formerly ICSH in males)
Parathyroid hormone	PTH
Prolactin	PRL
Somatotropin (human growth hormone or growth hormone)	STH (HGH or GH)
Thyroid stimulating hormone	TSH

### Pedigree Symbols

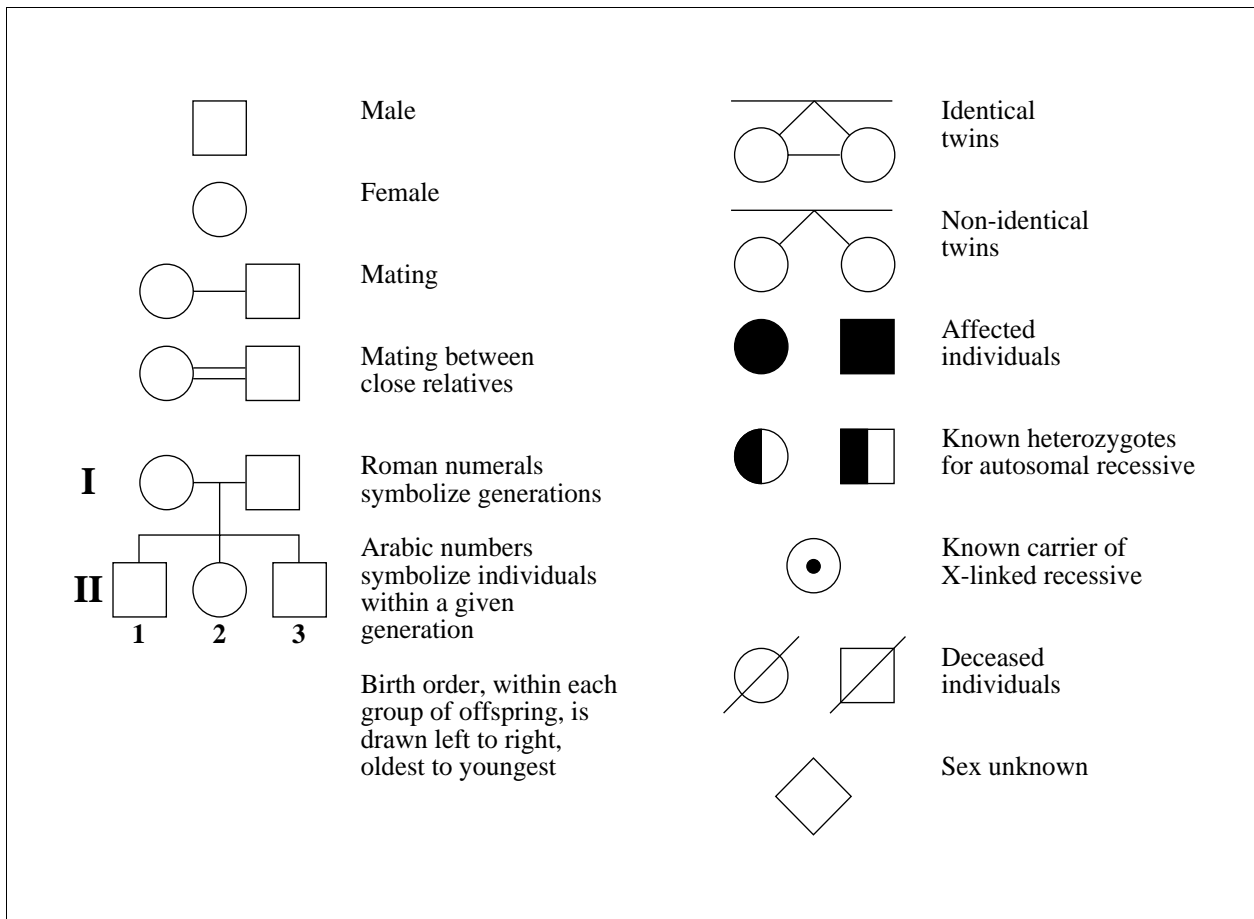



**Messenger RNA Codons and Their Corresponding Amino Acids**

First Base	Second Base				Third Base
	U	C	A	G	
U	UUU phenylalanine	UCU serine	UAU tyrosine	UGU cysteine	U
	UUC phenylalanine	UCC serine	UAC tyrosine	UGC cysteine	C
	UUA leucine	UCA serine	UAA stop **	UGA stop **	A
	UUG leucine	UCG serine	UAG stop **	UGG tryptophan	G
C	CUU leucine	CCU proline	CAU histidine	CGU arginine	U
	CUC leucine	CCC proline	CAC histidine	CGC arginine	C
	CUA leucine	CCA proline	CAA glutamine	CGA arginine	A
	CUG leucine	CCG proline	CAG glutamine	CGG arginine	G
A	AUU isoleucine	ACU threonine	AAU asparagine	AGU serine	U
	AUC isoleucine	ACC threonine	AAC asparagine	AGC serine	C
	AUA isoleucine	ACA threonine	AAA lysine	AGA arginine	A
	AUG methionine*	ACG threonine	AAG lysine	AGG arginine	G
G	GUU valine	GCU alanine	GAU aspartate	GGU glycine	U
	GUC valine	GCC alanine	GAC aspartate	GGC glycine	C
	GUA valine	GCA alanine	GAA glutamate	GGA glycine	A
	GUG valine	GCG alanine	GAG glutamate	GGG glycine	G

\* Note: AUG is an initiator codon and also codes for the amino acid methionine.

\*\* Note: UAA, UAG, and UGA are terminator codons.

**Information About Nitrogen Bases**

Nitrogen Base	Classification	Abbreviation
Adenine	Purine	A
Guanine	Purine	G
Cytosine	Pyrimidine	C
Thymine	Pyrimidine	T
Uracil	Pyrimidine	U

Fold and tear along perforation.



*No marks will be given for work done on this page.*

*Fold and tear along perforation.*

***Biology 30  
Diploma Examination  
June 1999***

***Multiple–Choice Key,  
Numerical–Response Key,  
and  
Sample Answers to  
Written–Response Questions***

**Biology June 1999 Diploma Examination  
Multiple Choice and Numerical Response Keys**

- |       |       |
|-------|-------|
| 1. D  | 25. C |
| 2. A  | 26. D |
| 3. C  | 27. A |
| 4. C  | 28. B |
| 5. D  | 29. B |
| 6. C  | 30. D |
| 7. D  | 31. C |
| 8. D  | 32. B |
| 9. D  | 33. D |
| 10. C | 34. C |
| 11. C | 35. A |
| 12. B | 36. A |
| 13. A | 37. C |
| 14. D | 38. B |
| 15. D | 39. D |
| 16. A | 40. B |
| 17. C | 41. B |
| 18. C | 42. A |
| 19. B | 43. A |
| 20. A | 44. B |
| 21. B | 45. A |
| 22. B | 46. D |
| 23. C | 47. D |
| 24. A | 48. C |

- |           |      |
|-----------|------|
| <b>1.</b> | 1342 |
| <b>2.</b> | 2431 |
| <b>3.</b> | 3214 |
| <b>4.</b> | 321  |
| <b>5.</b> | 0.50 |
| <b>6.</b> | 0    |
| <b>7.</b> | 0.2  |
| <b>8.</b> | 50   |

## ***Biology 30 June 1999 Diploma Examination Scoring Guide***

*Use the following information to answer the next question.*

On April 26, 1986, one of the worst technological, industrial, and environmental disasters known to humankind occurred. A nuclear reactor in Chernobyl exploded and showered radioactive debris over much of Eastern Europe. The extent of the environmental and health effects of the nuclear legacy of Chernobyl are still unknown.

Although the exact causes of many illnesses are not understood, there is little doubt that the enormous burst of radiation released from the reactor has had devastating effects on thousands of children. One of the most dangerous radioactive products released was iodine-131. It was inhaled by many children, exposing them to high levels of radiation. Iodine-131 was absorbed by the children's thyroid glands, causing inflammation of the gland and an increased incidence of thyroid cancer. Normally, iodine is absorbed from the blood by the thyroid gland in its synthesis of thyroxine.

The effects of this radiation over a long period of time were also studied. Researchers looked at DNA gene sequences five to 45 bases long from blood samples taken from parents and their children born in 1994 or later. They looked for any sequence in the child's DNA that did not occur in the blood cells of either parent. The children born near Chernobyl had twice as many of these mutations in their DNA as had the control group, which consisted of families in England whose children were also born in or after 1994.

—from *Monmaney, 1996*  
*Shcherbak, 1996*

**Written Response – 15%**

Staple your word-processed response for **this** question to this page.

- 1.** a. Explain one function of thyroxine. (1 mark)

*Any one of the following:*

- *stimulates/regulates metabolic processes (metabolism)*
- *stimulates/regulates cellular respiration (energy release, ATP production)*
- *stimulates/regulates heat production*
- *regulates body temperature*

- b. Draw a feedback loop that illustrates the regulation of the release of thyroxine. Include relevant glands and hormones. (3 marks)

*Alternative 1:*

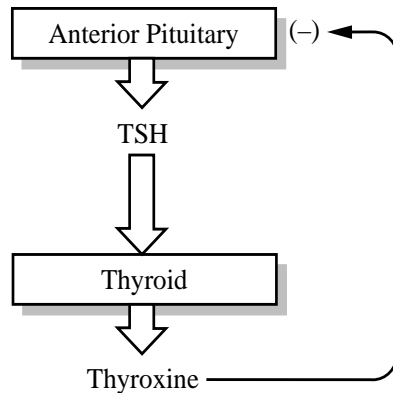

*Alternative 2:*

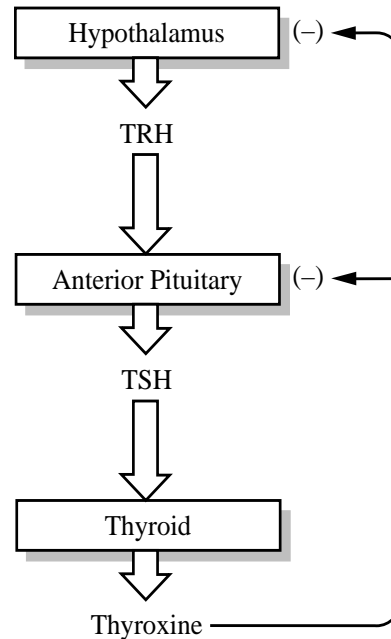

**For scoring:**

- pituitary and TSH (1 mark)
- thyroid gland and thyroxine (1 mark)
- appropriate stimulation and inhibition is indicated (1 mark)

- c. Thyroid cancer in infants can be treated by surgical removal of the thyroid gland. Identify **two** signs and/or symptoms that would indicate or would be caused by the absence of thyroxine in such an infant. (2 marks)

*Any two of the following:*

- |  |                               |
|--|-------------------------------|
| • low energy (lethargy) (fatigue) (sleepiness)       | • thick tongue, thick neck    |
| • low metabolic rate (low BMR)                       | • slowed heart rate           |
| • stunted growth and development (failure to thrive) | • constipation                |
| • blood test (low thyroxine, high TSH)               | • dry skin                    |
| • slowed mental development (cretinism)              | • puffiness in the face       |
| • obesity  | • increased blood cholesterol |
| • low body temperature                               | • decreased breathing rate    |

**Note:** If more than two are given, mark the first two only.

- d. The children exposed to radioactive iodine because of the nuclear accident were treated with high levels of non-radioactive iodine. Explain why this treatment was used. (1 mark)

Any one of the following:

- High levels of non-radioactive iodine will be absorbed in greater amounts than the radioactive iodine thereby reducing the effects of the radioactive iodine.
- The non-radioactive iodine will decrease the inflammation of the thyroid gland or decrease the incidence of thyroid cancer.
- Since part of the thyroid gland is destroyed, provision of non-radioactive iodine maximizes the production of thyroxine in the remaining functional portion of the thyroid gland.

- e. Describe and sketch one type of error at the molecular level of DNA that results in a mutation. (Create a hypothetical strand of DNA bases, then show the strand again, illustrating and clearly marking the change causing the error.) (3 marks)

Any one of these sketches of the mutation is acceptable.

	<i>Deletion</i>	<i>Insertion</i>	<i>Substitution</i>	<i>or</i>	<i>Any Pairing Error</i>
<i>was:</i>	T	T	T		
	G	G	G		
	C	C	C		A – T
	A	A	A		T – C
	T	T	T		T – A
	T	→ T	T		
	↓	↓	↓		
<i>becomes:</i>	T	T	T		
	G	G	G		
	C	C	C		
	→ T	A	T		
	T	T	T		
		A	T		
		T			

**For Scoring:**

- sketch of a DNA strand before and after mutation (1 mark)
- change in the DNA clearly indicated (1 mark)
- The description of the mutation must match student's sketch of the mutation. If the mutation sketched is correctly named then this can be considered to be a sufficient description. The mutation does not need to be named. (1 mark)



- f. The evidence presented in the last paragraph of the reading suggests that mutations occurred in one of the parents' germ-line cells (precursor cells to oocytes or sperm cells). Describe how the germ-line cell mutations appeared in the children's white blood cells. **(2 marks)**

*Germ cells (with mutations) combined in fertilization to form a zygote (fertilized egg) (1 mark). The zygote divided by mitosis to form all the cells of the new individual; therefore all cells, including white blood cells, contain the mutation(s) (1 mark).*

*Use the following information to answer the next question.*

There is a worldwide shortage of organs for transplanting into humans. Some researchers are concentrating on xenotransplantation—using organs from other species—as a solution.

The pig is considered by researchers as the most suitable donor of transplant organs for humans, even though pigs are not as closely related genetically to humans as higher primates are. Pigs can be bred easily and up to three times a year. Sows have short pregnancies (about 115 days) and give birth to large litters. The offspring grow quickly to reach a large size.

Transplanted organs from ordinary pigs are quickly rejected by the human immune system. Researchers have isolated a human gene, called HDAF, that codes for a cell membrane protein known as RCA. The human HDAF gene can be inserted into pig DNA so the human RCA protein will be present on the surface of pig cells. Human RCA protein on cell membranes of pig cells is expected to inhibit the rejection of pig organs when they are transplanted into humans. A pig that has the human gene in all of its cells is referred to as a transgenic pig.

Fertilized eggs are harvested from a sow

Injection of HDAF gene into the nuclei of the fertilized eggs

Transfer of injected eggs into recipient sows

**Unfortunately, it is not possible to gain permission for electronic publication of all the source material for this question.**

Identification of heterozygote transgenic offspring (shaded grey) expressing RCA protein in their organs

Identification of homozygote transgenic offspring (shaded dark grey) expressing RCA protein in their organs

- 2.** Write a unified response that addresses the following aspects of the use of pigs as a source of organs for transplantation.
- **Compare** the biotic potential of pig populations with that of other mammals, such as primates or humans. **Explain** how two traits of pigs would have influenced researchers to choose pigs as the most suitable animals for xenotransplantation.
  - **Describe** one technology that researchers would have used to obtain the HDAF gene. **Explain**, in detail, what happens after the HDAF gene is injected into fertilized eggs to produce heterozygote transgenic offspring and normal offspring.
  - **Explain** why researchers performed crosses of heterozygote offspring and **explain** the observed outcome of these crosses using a Punnett Square to clarify your explanation.

### *Suggested Answers*

#### *Biotic Potential Comparison*

*Pigs have a higher biotic potential than many other mammals of their size, e.g. humans or other primates because:*

- *pigs reach maturity at a younger age than primates and can therefore begin to produce offspring earlier*
- *pigs can be bred more than once per year (3 times) whereas primates can be bred only once a year*
- *pigs have many offspring per pregnancy as contrasted to primates which usually have only one offspring per pregnancy*
- *pigs have shorter gestation periods (115 days) than primates which allows them to have more litters per year*

#### *Researchers likely chose pigs for the following traits:*

*Any two of the following:*

- *the short turn-around time (short pregnancy term), many offspring per litter, 3 litters per year possible, reach sexual maturity earlier than primates; yields many organs for transplants or further research*
- *organs of adequate size are produced*
- *pigs have a similar physiology to humans*
- *other animals, such as primates, have more complex social interactions and researchers may have felt that using these animals as donors would have been ethically unacceptable*
- *used as a source of food already therefore more acceptable than using primate mammals*
- *relatively low cost due to high output*

- *pigs are quite different genetically from humans and therefore the transmission of disease from pigs to humans is less likely than if primates were used*
- Or any other acceptable considerations.*

## ***Technology***

*The student describes one of the following technologies that could have been used to obtain the HDAF gene.*

- *Restriction enzymes would have been used to cut out the HDAF gene from the human chromosome. These enzymes cut only specific sequences of DNA.*
  - *Gel electrophoresis could be used to separate human DNA for analysis and help to locate the HDAF gene.*
  - *Tissue sampling (such as blood sampling) would provide a source of human DNA from which to search for the gene or to detect expression of the RCA protein.*
  - *Chromosome mapping (gene mapping) can be used to identify the position of genes on a chromosome. This can then be used to identify a candidate for the HDAF gene.*
  - *Cloning of DNA would produce many copies of the desired gene to work with. Cloning can be achieved using recombinant bacteria or newer techniques such as PCR.*
- Or any other acceptable technology.*

## ***Outcome of HDAF Injection***

*After the HDAF gene is injected into a fertilized egg, the **fertilized egg's DNA may recombine** with the HDAF gene. If this occurs, every cell in the pig that arises from that fertilized egg will contain the HDAF gene. This produces the **heterozygote transgenic** offspring. **Normal** (non-transgenic) offspring arise when the fertilized egg's DNA **does not recombine with** the HDAF gene.*

## ***Crosses of Heterozygote Offspring***

*Crosses of heterozygote transgenic offspring were performed in order to produce offspring that were homozygous for the HDAF gene. The homozygous offspring could then be used for breeding stock to produce more homozygous transgenic pigs. These pigs would have organs that displayed more of the human RCA protein than the heterozygotes. Researchers would want to use these organs in transplant trials since they would be less likely to be rejected by the recipient than the organs from heterozygote pigs or non-transgenic pigs.*

***Punnett Square:***

$$\text{HDAF}^+ \text{HDAF}^- \times \text{HDAF}^+ \text{HDAF}^-$$

	HDAF <sup>+</sup>	HDAF <sup>-</sup>
HDAF <sup>+</sup>	HDAF <sup>+</sup> HDAF <sup>+</sup>	HDAF <sup>+</sup> HDAF <sup>-</sup>
HDAF <sup>-</sup>	HDAF <sup>+</sup> HDAF <sup>-</sup>	HDAF <sup>-</sup> HDAF <sup>-</sup>

*The offspring of a cross between two heterozygous pigs would produce homozygous transgenic pigs (HDAF<sup>+</sup> HDAF<sup>+</sup>) expressing the RCA protein in their organs (1/4), heterozygous transgenic pigs (HDAF<sup>+</sup> HDAF<sup>-</sup>) (1/2), and homozygous non-transgenic pigs (HDAF<sup>-</sup> HDAF<sup>-</sup>) (1/4).*

## Science

Score	Scoring Criteria
<p style="text-align: center;"><b>5</b> <b>Excellent</b></p>	<p><b>The student...</b></p> <ul style="list-style-type: none"> <li>• compares the biotic potential of pigs to another mammal by using a comparative word (higher, lower, or the same as) <b>and</b> two specific descriptions of factors that affect their biotic potential.</li> <li>• identifies two traits of pigs <b>and</b> clearly explains how each influenced researchers to choose pigs for xenotransplantation</li> <li>• clearly explains why the heterozygote crosses were performed <b>and</b> clearly communicates the outcome of the crosses using a Punnett square.</li> </ul>
<p style="text-align: center;"><b>4</b> <b>Proficient</b></p>	<ul style="list-style-type: none"> <li>• compares the biotic potential of pigs to another mammal by using a comparative word <b>and</b> one specific description of a factor that affects their biotic potential.</li> <li>• identifies two traits of pigs <b>and</b> clearly explains how one of these traits influenced researchers to choose pigs <b>or</b> partially explains how each influenced the researchers choice.</li> <li>• explains why the heterozygote crosses were performed <b>and</b> partially communicates the outcome of the crosses using a Punnett square <b>or</b> partially explains why the heterozygote crosses were performed <b>and</b> clearly communicates the outcome of the crosses using a Punnett square.</li> </ul>
<p style="text-align: center;"><b>3</b> <b>Satisfactory</b></p>	<ul style="list-style-type: none"> <li>• compares the biotic potential of pigs to another mammal using a comparative word <b>or</b> implies a comparison of the biotic potential of pigs to primates by giving one example of a unique factor that affects a pig's biotic potential that is different in primates.</li> <li>• identifies two traits of pigs that may have influenced researchers to choose pigs for xenotransplantation <b>or</b> identifies one trait of pigs <b>and</b> explains how it influenced researchers choice.</li> <li>• explains why the heterozygote crosses were performed <b>or</b> partially communicates the outcome of the crosses using a Punnett square.</li> </ul>
<p style="text-align: center;"><b>2</b> <b>Limited</b></p>	<ul style="list-style-type: none"> <li>• attempts to compare the biotic potential of pigs to another mammal</li> <li>• identifies one trait of pigs that may have influenced researchers to choose pigs for xenotransplantation.</li> <li>• partially explains why the heterozygote crosses were performed <b>or</b> attempts a Punnett square for a heterozygote cross.</li> </ul>
<p style="text-align: center;"><b>1</b> <b>Poor</b></p>	<ul style="list-style-type: none"> <li>• addresses only one of the three scoring bullets at a 3 or 2 level.</li> </ul>

**INSUFFICIENT** is a special category. It is not an indication of quality. It should be assigned to papers that do not contain a discernible attempt to address the questions presented in the assignment or that are too brief to assess in this or any other scoring category.

## Technology and Society

Score	Scoring Criteria
<p style="text-align: center;"><b>5</b> <b>Excellent</b></p>	<p><b>The student...</b></p> <ul style="list-style-type: none"> <li>• clearly describes one technology and how it could have been used to obtain the HDAF gene for research.</li> <li>• clearly explains how heterozygote and normal offspring are produced after injection of the HDAF gene into the fertilized egg.</li> </ul>
<p style="text-align: center;"><b>4</b> <b>Proficient</b></p>	<ul style="list-style-type: none"> <li>• describes one technology that could have been used to obtain the HDAF gene for research.</li> <li>• explains how either heterozygote <b>or</b> normal offspring are produced <b>and</b> suggests how the other is produced after injection of the HDAF gene into the fertilized egg.</li> </ul>
<p style="text-align: center;"><b>3</b> <b>Satisfactory</b></p>	<ul style="list-style-type: none"> <li>• identifies one technology that could have been used to obtain the HDAF gene for research</li> <li>• explains how either the heterozygote <b>or</b> normal offspring are produced.</li> </ul>
<p style="text-align: center;"><b>2</b> <b>Limited</b></p>	<ul style="list-style-type: none"> <li>• describes or identifies a technology that may have been used during the experiment that is not related to obtaining the HDAF gene for research.</li> <li>• attempts to explain how the insertion of the HDAF gene would produce either heterozygote or normal offspring.</li> </ul>
<p style="text-align: center;"><b>1</b> <b>Poor</b></p>	<ul style="list-style-type: none"> <li>• addresses one of the two scoring bullets at a 2 level.</li> </ul>

**INSUFFICIENT** is a special category. It is not an indication of quality. It should be assigned to papers that do not contain a discernible attempt to address the questions presented in the assignment or that are too brief to assess in this or any other scoring category.